

Keysight N8839A Hybrid Memory Cube Compliance Test Application

Notices

© Keysight Technologies, Inc. 2014-2016

No part of this manual may be reproduced in any form or by any means (including electronic storage and retrieval or translation into a foreign language) without prior agreement and written consent from Keysight Technologies, Inc. as governed by United States and international copyright laws.

Revision

Version 01.00.0000 or greater

Edition

February 3, 2016

Available in electronic format only

Published by:

Keysight Technologies, Inc.
1900 Garden of the Gods Road
Colorado Springs, CO 80907 USA

Warranty

The material contained in this document is provided "as is," and is subject to being changed, without notice, in future editions. Further, to the maximum extent permitted by applicable law, Keysight disclaims all warranties, either express or implied, with regard to this manual and any information contained herein, including but not limited to the implied warranties of merchantability and fitness for a particular purpose. Keysight shall not be liable for errors or for incidental or consequential damages in connection with the furnishing, use, or performance of this document or of any information contained herein. Should Keysight and the user have a separate written agreement with warranty terms covering the material in this document that conflict with these terms, the warranty terms in the separate agreement shall control.

Technology License

The hardware and/or software described in this document are furnished under a license and may be used or copied only in accordance with the terms of such license.

U.S. Government Rights

The Software is "commercial computer software," as defined by Federal Acquisition Regulation ("FAR") 2.101. Pursuant to FAR 12.212 and 27.405-3 and Department of Defense FAR Supplement ("DFARS") 227.7202, the U.S. government acquires commercial computer software under the same terms by which the software is customarily provided to the public. Accordingly, Keysight provides the Software to U.S. government customers under its standard commercial license, which is embodied in its End User License Agreement (EULA), a copy of which can be found at www.keysight.com/find/sweula. The license set forth in the EULA represents the exclusive authority by which the U.S. government may use, modify, distribute, or disclose the Software. The EULA and the license set forth therein, does not require or permit, among other things, that Keysight: (1) Furnish technical information related to commercial computer software or commercial computer software documentation that is not customarily provided to the public; or (2) Relinquish to, or otherwise provide, the government rights in excess of these rights customarily provided to the public to use, modify, reproduce, release, perform, display, or disclose commercial computer software or commercial computer software documentation. No additional government requirements beyond those set forth in the EULA shall apply, except to the extent that those terms, rights, or licenses are explicitly required from all providers of commercial computer software pursuant to the FAR and the DFARS and are set forth specifically in writing elsewhere in the EULA. Keysight shall be under no obligation to update, revise or otherwise modify the Software. With respect to any technical data as defined by FAR 2.101, pursuant to FAR 12.211 and 27.404.2 and DFARS 227.7102, the U.S. government acquires no greater than Limited Rights as defined in FAR 27.401 or DFAR 227.7103-5 (c), as applicable in any technical data.

Safety Notices

CAUTION

A **CAUTION** notice denotes a hazard. It calls attention to an operating procedure, practice, or the like that, if not correctly performed or adhered to, could result in damage to the product or loss of important data. Do not proceed beyond a **CAUTION** notice until the indicated conditions are fully understood and met.

WARNING

A **WARNING** notice denotes a hazard. It calls attention to an operating procedure, practice, or the like that, if not correctly performed or adhered to, could result in personal injury or death. Do not proceed beyond a **WARNING** notice until the indicated conditions are fully understood and met.

Hybrid Memory Cube Compliance Test Application—At a Glance

The Keysight N8839A Hybrid Memory Cube Compliance Test Application is a test solution that covers the electrical timing parameters for Hybrid Memory Cube Specification 2.1.

The Hybrid Memory Cube Compliance Test Application:

- Lets you select individual or multiple tests to run.
- Lets you identify the device being tested and its configuration.
- Shows you how to make oscilloscope connections to the device under test.
- Automatically checks for proper oscilloscope configuration.
- Automatically sets up the oscilloscope for each test.
- Allows you to determine the number of trials for each test.
- Provides detailed information of each test that has been run. The result of maximum 64 worst trials can be displayed at any one time.
- Creates a printable HTML report of the tests that have been run. This report includes pass/fail limits, margin analysis, and screen shots.

Required Equipment and Software

In order to run the Hybrid Memory Cube automated tests, you need the following equipment and software:

Product	Description	Notes
DSO/DSAZ504A	Infiniium Oscilloscope: 50 GHz	45 GHz and above for 30 Gb/s data rate
N8839A-1FP, or	HMC Compliance Test Software, fixed perpetual license	Required
N5435A-101	HMC Compliance Test Software, server based license	
N8839A-7FP, or	Switch matrix option, fixed perpetual license	Optional
N5435A-717	Switch matrix option, server based license	
E2688A-1FP	Serial data analysis software	Required
N5400A-1FP	EZJIT Plus Software	Required
N5465A-1FP	InfiniiSim Software – Advanced license	Recommended for probe correction
N5234A	Network analyzer, 43.5 GHz	Required for up to 30 Gb/s return loss testing

Contents

Hybrid Memory Cube Compliance Test Application—At a Glance / 3

1 Installing the N8839A Compliance Test Application

Installing the Software / 8

Installing the License Key / 9

2 Preparing to Take Measurements

Calibrating the Oscilloscope / 12

Starting the Compliance Test Application / 13

3 Main Voltage Measurements (pattern: Square 64)

DC Common Mode Output Voltage Test / 18

AC Common Mode Noise - Square Wave Test / 19

Differential Peak-to-Peak Output Voltage Test / 20

4 Jitter and Signaling Rate Measurements (pattern: PRBS15)

AC Common Mode Noise - PRBS Test / 24

Signaling Rate / 25

Jitter (DJ-Tx, DCD-Tx, RJ-Tx, TJ-Tx) / 26

5 REFCLK Measurements (pattern: Clock)

fREFCLK / 29

tDCD_REFCLK / 30

6 Return Loss ENA/PNA Measurements

7 Debug Mode

A Calibrating the Infiniium Oscilloscope and Probe

Oscilloscope Internal Calibration / 36

Probe Calibration / 37

Index

1 Installing the N8839A Compliance Test Application

Installing the Software / 8

Installing the License Key / 9

If you purchased the N8839A Compliance Test Application separate from your Infiniium oscilloscope, you need to install the software and license key.

Installing the Software

- 1 Make sure you have the minimum version of Infiniium oscilloscope software (see the N8839A release notes) by choosing **Help > About Infiniium...** from the main menu.
- 2 To obtain the N8839A Compliance Test Application, go to Keysight website: <http://www.keysight.com/support/N8839A>
- 3 The link for N8839A Hybrid Memory Cube Compliance Test Application will appear. Double-click on it and follow the instructions to download and install the application software.

Installing the License Key

- 1 Request a license code from Keysight by following the instructions on the Entitlement Certificate.

You will need the oscilloscope's "Option ID Number", which you can find in the **Help > About Infiniium...** dialog box.

- 2 After you receive your license code from Keysight, choose **Utilities > Install Option License...**
- 3 In the Install Option License dialog box, enter your license code and click **Install License**.
- 4 Click **OK** in the dialog box that tells you to restart the Infiniium oscilloscope application software to complete the license installation.
- 5 Click **Close** to close the Install Option License dialog box.
- 6 Choose **File > Exit**.
- 7 Restart the Infiniium oscilloscope application software to complete the license installation.

1 Installing the N8839A Compliance Test Application

2 Preparing to Take Measurements

Calibrating the Oscilloscope / 12

Starting the Compliance Test Application / 13

Before running the automated tests, you should calibrate the oscilloscope and probe. No test fixture is required for this application. After the oscilloscope and probe have been calibrated, you are ready to start the N8839A Compliance Test Application and perform the measurements.

Calibrating the Oscilloscope

If you haven't already calibrated the oscilloscope, see [Appendix A](#), "Calibrating the Infiniium Oscilloscope and Probe," starting on page 35.

NOTE

If the ambient temperature changes more than 5 degrees Celsius from the calibration temperature, internal calibration should be performed again. The delta between the calibration temperature and the present operating temperature is shown in the **Utilities > Calibration** menu.

NOTE

If you switch cables between channels or other oscilloscopes, it is necessary to perform cable and probe calibration again. Keysight recommends that, once calibration is performed, you label the cables with the channel on which they were calibrated.

Starting the Compliance Test Application

- 1 Ensure that the Device Under Test (DUT) is operating and set to desired test modes.
- 2 To start the Compliance Test Application: From the Infiniium oscilloscope's main menu, choose **Analyze > Automated Test Apps > N8839A Hybrid Memory Cube Test App**.

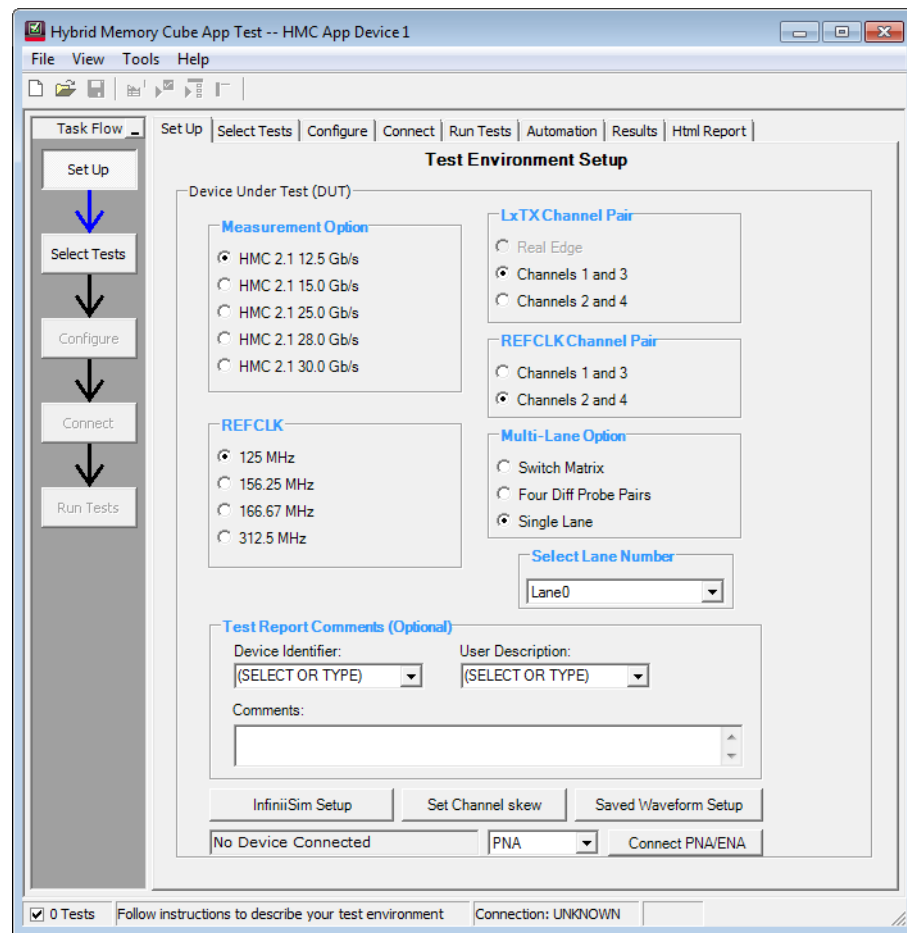

Figure 1 N8839A Compliance Test Application Main Window

The task flow pane, and the tabs in the main pane, show the steps you take in running the automated tests:

Set Up	<p>Lets you identify and set up the test environment, including information about the device under test.</p> <p>The Device Identifier, User Description, and Comments are all printed in the final HTML report.</p> <p>Select the device speed to be tested.</p> <p>Set up InfiniiSim with the InfiniiSim Setup button.</p> <p>With the Set Channel skew button, the channels can be visually adjusted and skewed.</p> <p>The Saved Waveform Setup button enables easy setup of saved waveforms. When waveforms are set up, the application will make all measurements on the saved waveforms.</p> <p>The Multi-Lane Option enables you to choose to test a single lane or with the switch matrix.</p>
Select Tests	<p>Lets you select the tests you want to run. The tests are organized hierarchically so you can select all tests in a group. After tests are run, status indicators show which tests have passed, failed, or not been run, and there are indicators for the test groups.</p>
Configure	<p>Lets you configure test parameters (for example, channels used in test, Number of UI to test, oscilloscope bandwidth, fixed Rj, etc.).</p>
Connect	<p>Shows you how to connect the oscilloscope to the device under test for the tests that are to be run.</p>
Run Tests	<p>Starts the automated tests. If the connections to the device under test need to be changed while multiple tests are running, the tests pause, show you how to change the connection, and wait for you to confirm that the connections have been changed before continuing.</p>
Automation	<p>Lets you construct scripts of commands that drive execution of the application.</p>
Results	<p>Contains more detailed information about the tests that have been run. You can change the thresholds at which marginal or critical warnings appear.</p>
HTML Report	<p>Shows a compliance test report that can be printed.</p>

3 Main Voltage Measurements (pattern: Square 64)

DC Common Mode Output Voltage Test / 18

AC Common Mode Noise - Square Wave Test / 19

Differential Peak-to-Peak Output Voltage Test / 20

This section provides the Methods of Implementation (MOIs) for the Hybrid Memory Cube Main Voltage Measurements using a Keysight Infiniium oscilloscope and the N8839A Compliance Test Application.

Probing and Connection

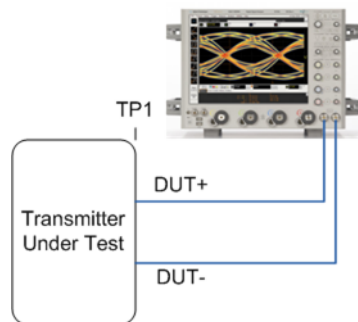

Figure 2 Probing for Main Voltage Measurements

You can use any of the oscilloscope channels as the signal source channel; however, for proper BW, use the Real Edge channels for 25 Gb/s and greater. Select lane options in the **Setup** tab. You can identify the channels used for the measurement signal in the **Setup** tab of the Compliance Test Application.

- Test Procedure**
- 1 Start the automated test application as described in "**Starting the Compliance Test Application**" on page 13.
 - 2 Connect the probes to the signals on the DUT.
 - 3 Connect the oscilloscope probes or cables to the channel(s) of the oscilloscope that you have set up in the **Configuration** tab.

- 4 In the Test application, click the **Set Up** tab. Select **Measurement Option, Lane Option, and Channels**.
- 5 Set up Switch matrix (if used) by clicking on the **Switch Matrix Setup** button.
- 6 Set up InfiniiSim if needed.
- 7 Type in or select the **Device Identifier** as well as the **User Description** from the drop-down list. Enter your comments in the **Comments** text box.
- 8 Click the **Select Tests** tab and check the tests you want to run. Check the parent node or group to check all the available tests within the group.

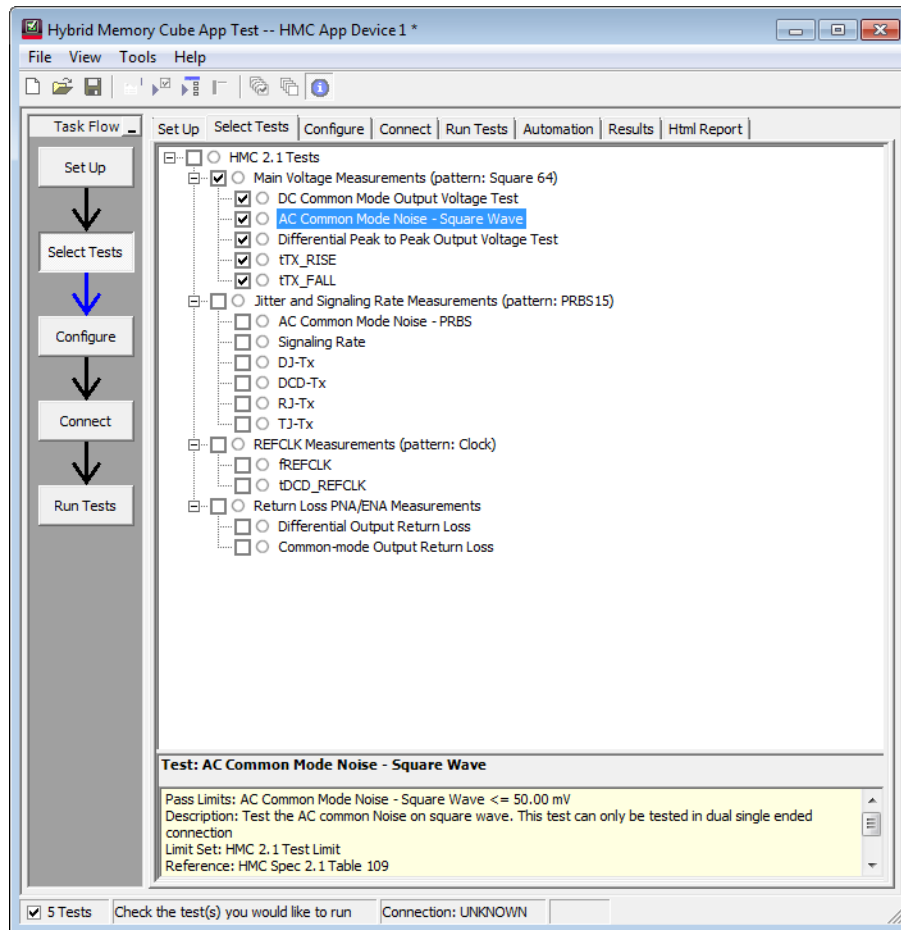

Figure 3 Selecting Main Voltage Measurement Tests

Main Voltage Specifications (pattern: Square 64)

The Hybrid Memory Cube specifications can be found in Hybrid Memory Cube Spec 2.1 Table 109.

- DC Common Mode Output Voltage (392.85 mV to 509.85 mV)
- AC Common Mode Noise – Square Wave (max 50 mVp-p)
- Differential Peak to Peak Output Voltage (750 mV to 1.025 V)

- tTX_RISE (min 8 ps)
- tTX_FALL (min 8 ps)

DC Common Mode Output Voltage Test

The purpose of this test is to verify that the common mode signal of the differential pair is between 392.85 mV and 509.85 mV.

NOTE

This measurement can be done only with a dual-single ended connection; it cannot be done with a differential probing connection.

PASS Condition The signal is between 392.85 mV and 509.85 mV.

Measurement Algorithm

- 1 Obtain sample or acquire signal data.
- 2 Verify that there is a signal and that the connection is dual-single ended.
- 3 Measure the min and max voltages of channel $(1+3)/2$ or channel $(2+4)/2$.
- 4 Compare the min and max voltage measurement to 392.85 mV-509.85 mV and report margin.

AC Common Mode Noise - Square Wave Test

The purpose of this test is to verify that the common mode signal of the differential pair peak-to-peak voltage does not exceed 50 mV on a Square 64 pattern.

NOTE

This measurement can be done only with dual-single ended connection; it cannot be done with a differential probing connection.

This test uses the square wave and measures peak to peak of the signal. The "**AC Common Mode Noise - PRBS Test**" on page 24 will test the rms voltage.

PASS Condition The signal is less than 50 mV.

Measurement Algorithm

- 1 Obtain sample or acquire signal data.
- 2 Verify that there is a signal and that the connection is dual-single ended.
- 3 Measure the peak-to-peak voltage of the channel $(1+3)/2$ or channel $(2+4)/2$.
- 4 Compare the voltage measurement to 50 mV and report the margin.

Differential Peak-to-Peak Output Voltage Test

The purpose of this test is to verify that the peak to peak voltage of the differential signal on a Square 64 pattern is between 750 mV and 1.025 V.

PASS Condition The differential signal max peak to peak voltage on a Square 64 pattern is between 750 mV-1.025 V.

- Measurement Algorithm**
- 1** Obtain sample or acquire signal data.
 - 2** Verify that there is a signal is connected and has a Square 64 pattern.
 - 3** Measure the peak to peak voltage of the differential signal of DUT+ and DUT-.
 - 4** Compare the max peak to peak voltage to 750 mV-1.025 V and report margin.

4 Jitter and Signaling Rate Measurements (pattern: PRBS15)

AC Common Mode Noise - PRBS Test / 24

Signaling Rate / 25

Jitter (DJ-Tx, DCD-Tx, RJ-Tx, TJ-Tx) / 26

This section provides the Methods of Implementation (MOIs) for the Jitter and Signaling Rate Measurements using a Keysight Infiniium oscilloscope and the N8839A Hybrid Memory Cube Compliance Test Application.

Probing and Connection

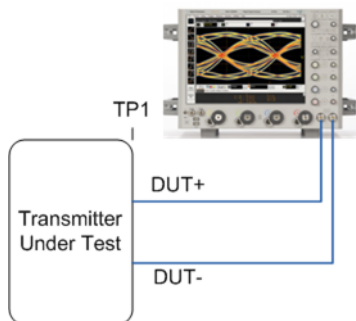

Figure 4 Probing for Jitter and Signaling Rate Measurements

You can use any of the oscilloscope channels as the signal source channel; however, for proper BW, use the Real Edge channels for 15 Gb/s and greater. Select lane options in the **Setup** tab. You can identify the channels used for the measurement signal in the **Setup** tab of the Compliance Test Application.

- Test Procedure**
- 1 Start the automated test application as described in "**Starting the Compliance Test Application**" on page 13.
 - 2 Connect the probes to the signals on the DUT.

- 3 Connect the oscilloscope probes or cables to the channel(s) of the oscilloscope that you have set up in the **Configuration** tab.
- 4 In the Test application, click the **Set Up** tab. Select **Measurement Option**, **Lane Option**, and **Channels**.
- 5 Set up Switch matrix (if used) by clicking on the **Switch Matrix Setup** button.
- 6 Set up InfiniiSim if needed.
- 7 Type in or select the **Device Identifier** as well as the **User Description** from the drop-down list. Enter your comments in the **Comments** text box.
- 8 Click the **Select Tests** tab and check the tests you want to run. Check the parent node or group to check all the available tests within the group.
- 9 In the **Configure** tab, select **Source for Rj**. This can be either the default **EZJIT** to measure Rj, or **User Defined** to use a fixed RJ.

If **User Defined** is selected, enter a value for **Fixed Rj Value**. Note: this Rj value is the Rj(rms) value.

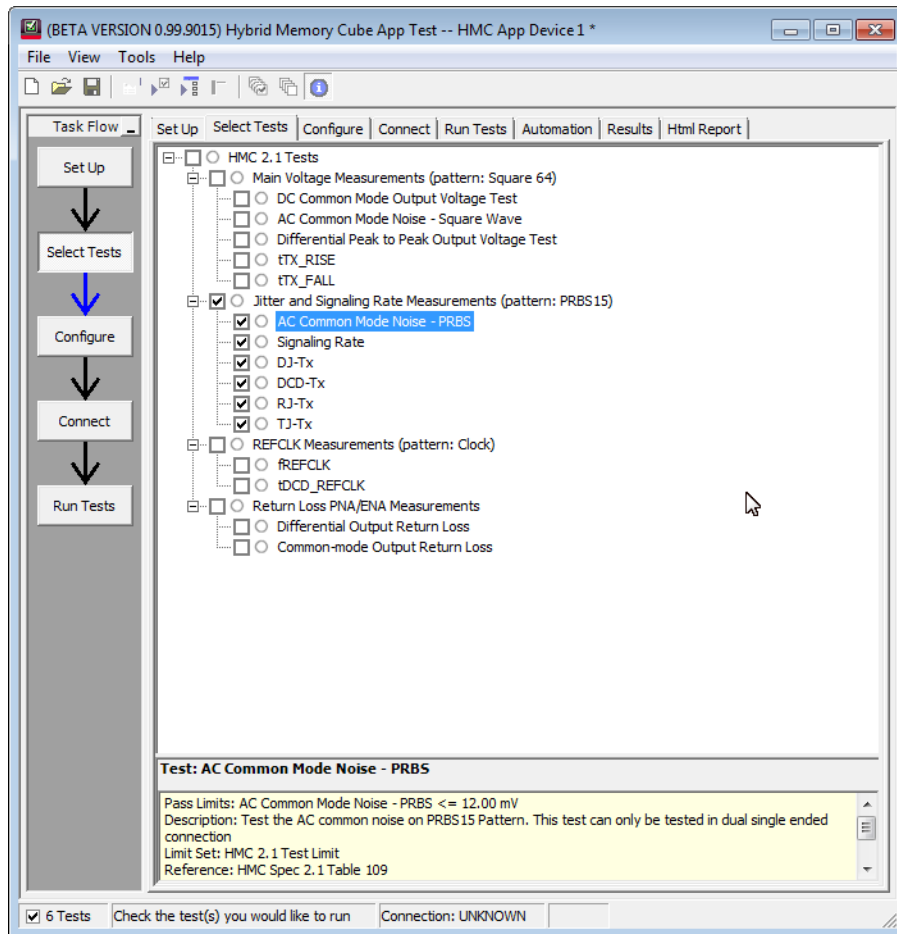

Figure 5 Selecting Jitter and Signaling Rate Tests

**Jitter and
Signaling Rate
Specifications
(pattern: PRBS15)**

The Hybrid Memory Cube specifications can be found in Hybrid Memory Cube Spec 2.1 Table 109.

- AC Common Mode Noise – PRBS (max 12 mV)
- Signaling Rate (fb \pm 100 ppm GBd)
- Max output jitter:
 - DJ-Tx (max 150 mUI)
 - DCD-Tx (max 35 mUI)
 - RJ-Tx (max 150 mUI p-p)
 - TJ-Tx (max 280 mUI)

AC Common Mode Noise - PRBS Test

The purpose of this test is to verify that the common mode signal of the differential pair peak to peak voltage does not exceed 12 mVrms on a PRBS15 pattern.

NOTE

This measurement can be done only with dual-single ended connection; it cannot be done with a differential probing connection.

PASS Condition The signal is less than 12 mV.

Measurement Algorithm

- 1 Obtain sample or acquire signal data.
- 2 Verify that there is a signal and that the connection is dual-single ended.
- 3 Measure the rms voltage of the channel $(1+3)/2$ or channel $(2+4)/2$.
- 4 Compare the voltage measurement to 12 mV and report the margin.

Signaling Rate

The purpose of this test is to verify that the signaling rate mean is between fb ± 100 ppm GBd.

PASS Condition The mean signaling rate is between fb ± 100 ppm GBd.

- Measurement Algorithm**
- 1** Obtain sample or acquire signal data.
 - 2** Check that signal is connected and data pattern exists (PRBS15).
 - 3** Set memory depth to capture the number of UI set in the configuration tab.
 - 4** Set data rate measurement to semi-automatic $f = fb$.
 - 5** Measure min, max, mean data rate.
 - 6** Report min and max values.
 - 7** Compare and report the mean data rate value to fb ± 100 ppm GBd.

Jitter (DJ-Tx, DCD-Tx, RJ-Tx, TJ-Tx)

The purpose of this test is to verify that differential signal's DJ-Tx Jitter is less than 150 mUI, DCD-Tx Jitter is less than 35 mUI, RJ-Tx Jitter is less than 150 mUI p-p at BER 1E-15, and TJ-Tx Jitter is less than 280 mUI at BER 1E-15. If all tests are selected, all tests are run on a single measurement. Each test can be run individually by selecting any or some of the tests.

PASS Conditions DJ-Tx Jitter is less than 150 mUI, DCD-Tx Jitter is less than 35 mUI, RJ-Tx Jitter is less than 150 mUI p-p at BER 1E-15, and TJ-Tx Jitter is less than 280 mUI at BER 1E-15.

- Measurement Algorithm**
- 1 In the **Configure** tab, select **Source fo Rj**. This can be either the default **EZJIT** to measure Rj, or **User Defined** to use a fixed RJ.
 If **User Defined** is selected, enter a value for **Fixed Rj Value**. Note: this Rj value is the Rj(rms) value.
 - 2 Obtain sample or acquire signal data.
 - 3 Check that signal is connected and data pattern exists (PRBS15).
 - 4 Set memory depth to capture the number of UI set in the configuration tab.
 - 5 Set clock recovery to OJTF First Order PLL with Nominal Data Rate $f=fb$ and Loop Bandwidth to $fb/2578$.
 - 6 If using EZJIT, with EZJIT Complete, measure DJ-Tx, DCD-Tx, RJ-Tx p-p at BER 1E-15, and TJ-Tx at BER of 10E-15.
 - 7 If using User Defined fixed Rj, measure DJ-Tx and DCD-Tx with EZJIT Complete, use fixed Rj(rms) value to calculate RJ-Tx to BER 1E-15 and using measured DJ-Tx and calculated RJ-Tx, calculate TJ-Tx to BER 1E-15.
 - 8 Compare and report the values to their respective maximum specification.

5 REFCLK Measurements (pattern: Clock)

fREFCLK / 29
tDCD_REFCLK / 30

This section provides the Methods of Implementation (MOIs) for the Reference clock measurements using the Keysight Infiniium oscilloscope and the N8839A Hybrid Memory Cube Compliance Test Application.

Probing and Connection

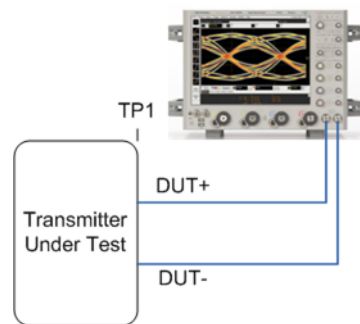

Figure 6 Probing for REFCLK Measurements

You can use any of the oscilloscope channels as the signal source channel. You can identify the channels used for the measurement signal in the **Setup** tab of the Compliance Test Application. For faster testing, select a different channel pair for REFCLK than for the rest of the tests.

- Test Procedure**
- 1 Start the automated test application as described in "**Starting the Compliance Test Application**" on page 13.
 - 2 Connect the probes to the signals on the DUT.
 - 3 Connect the oscilloscope probes or cables to the channel(s) of the oscilloscope that you have set up in the **Configuration** tab.

- 4 In the Test application, click the **Set Up** tab. Select **Measurement Option, Lane Option, and Channels**.
- 5 Set up Switch matrix (if used) by clicking on the **Switch Matrix Setup** button.
- 6 Set up InfiniiSim if needed.
- 7 Type in or select the **Device Identifier** as well as the **User Description** from the drop-down list. Enter your comments in the **Comments** text box.
- 8 Select the REFCLK frequency.
- 9 Click the **Select Tests** tab and check the tests you want to run. Check the parent node or group to check all the available tests within the group.

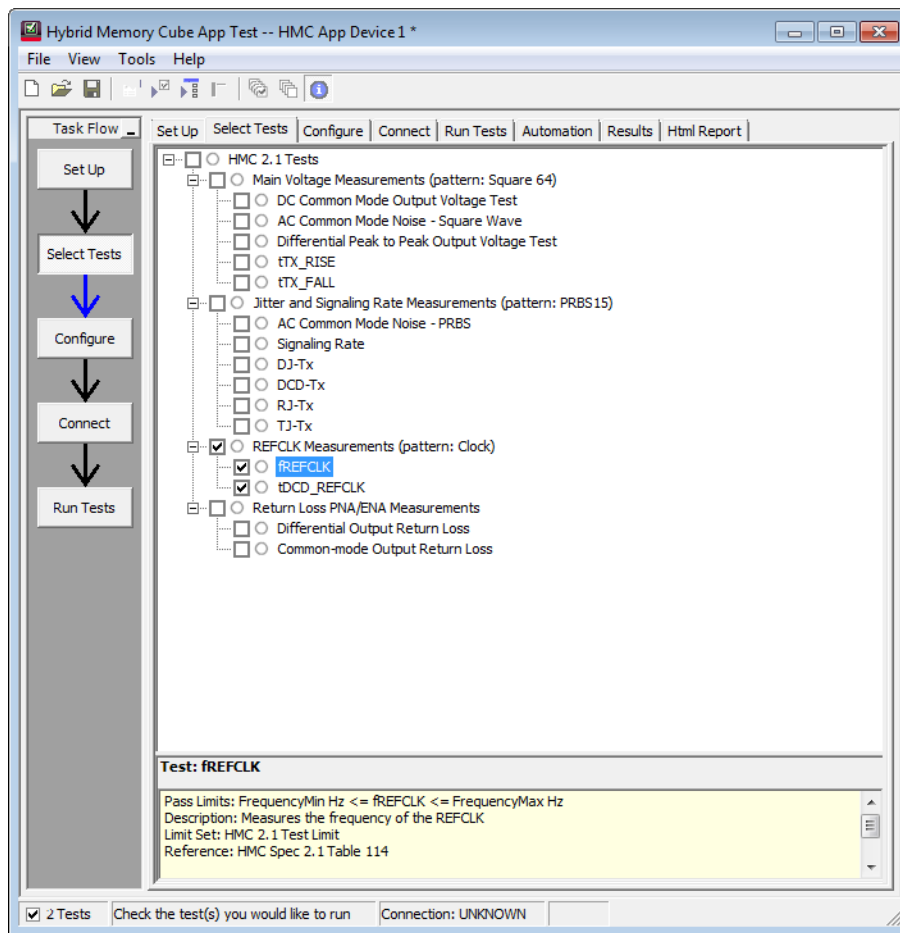

Figure 7 Selecting REFCLK Measurements

REFCLK Specifications

The REFCLK specifications can be found in Hybrid Memory Cube Spec 2.1 Table 114.

- fREFCLK ($f \pm 100$ ppm MHz)
- tDCD_REFCLK (45%–55%)

fREFCLK

The purpose of this test is to verify that the frequency mean is between $f \pm 100$ ppm MHz.

PASS Condition The mean data rate is between $f \pm 100$ ppm MHz.

- Measurement Algorithm**
- 1 Obtain sample or acquire signal data.
 - 2 Measure min, max, mean frequency on rising edge.
 - 3 Report min and max values.
 - 4 Compare and report the mean frequency value to $f \pm 100$ ppm MHz.

tDCD_REFCLK

The purpose of this test is to verify that the duty cycle is between 45%-55%.

PASS Condition The min and max duty cycle is between 45%-55%.

- Measurement Algorithm**
- 1** Obtain sample or acquire signal data.
 - 2** Measure min, max, mean duty cycle from rising to rising edge.
 - 3** Report mean value.
 - 4** Compare and report the min and max duty cycle measurements to 45%-55%.

6 Return Loss ENA/PNA Measurements

This section provides the Methods of Implementation (MOIs) for the Return Loss Measurements using a Keysight Infiniium oscilloscope, PNA or ENA, and the N8839A Compliance Test Application. The Compliance test application controls the PNA/ENA to set the test limits and run the test. The calibration must be done on the PNA/ENA.

- Test Procedure**
- 1 Start the automated test application as described in "**Starting the Compliance Test Application**" on page 13.
 - 2 Calibrate the PNA or ENA.
 - 3 Type in or select the **Device Identifier** as well as the **User Description** from the drop-down list. Enter your comments in the **Comments** text box.
 - 4 Click the **Select Tests** tab and check the tests you want to run. Check the parent node or group to check all the available tests within the group.
 - 5 Press **Run**. The test limits are automatically calculated.

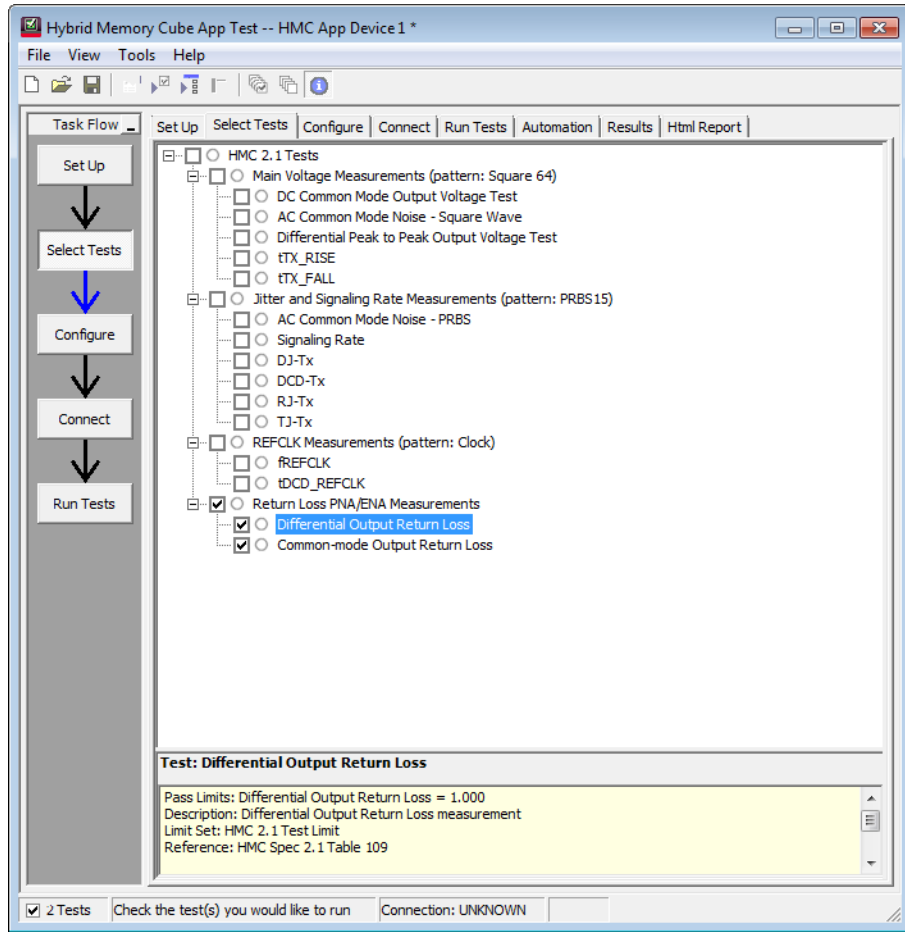

Figure 8 Selecting Return Loss Measurement

7 Debug Mode

Debug mode can be selected to enable the ability to change jitter measurement options. In the **Configuration** tab, select the **Debug** radio button. This will add the following options:

- **Rj Band width** – Choose the Rj Filter. Options are Narrow (Pink) or Wide (White). This changes the amount of DC jitter in the Rj measurement.
- **Jitter Pattern Length** – Choose Periodic or Arbitrary. Periodic is used for data patterns that are periodic and repeat through the oscilloscope memory. Arbitrary is used for random data patterns or long data patterns (for example, PRBS31) that do not repeat through the oscilloscope memory. If Arbitrary is selected, set the ISI filters.
- **ISI Filter Lead** – When using Arbitrary mode for the Jitter Pattern Length, set the Leading ISI filter coefficient. To help select the correct ISI filter, see **Application Note 1574: Choosing the ISI Filter Size for EZJIT Plus Arbitrary Data Jitter Analysis** (at www.keysight.com, literature part number 5989-4974EN).
- **ISI Filter Lag** – When using Arbitrary mode for the Jitter Pattern Length, set the Lagging ISI filter coefficient. Again, to help select the correct ISI filter, see **Application Note 1574: Choosing the ISI Filter Size for EZJIT Plus Arbitrary Data Jitter Analysis**.

A Calibrating the Infiniium Oscilloscope and Probe

Oscilloscope Internal Calibration / 36

Probe Calibration / 37

This section tells where to find information on oscilloscope and probe calibration procedures.

Oscilloscope Internal Calibration

For information on performing the internal diagnostic and calibration cycle for your Keysight Infiniium oscilloscope, refer to the "User Calibration" topic in your oscilloscope's online help.

Probe Calibration

Before performing the automated tests, you should calibrate the probes. Calibration of the solder-in probe heads consists of a vertical calibration and a skew calibration. The vertical calibration should be performed before the skew calibration. Both calibrations should be performed for best probe measurement performance.

For information on performing probe vertical and skew calibration in your Keysight Infiniium oscilloscope, refer to the "DC Attenuation/Offset Calibration" and "Skew Calibration" topics in your oscilloscope's online help.

For more information on calibration/deskew procedures for your particular probe, refer to the probe's *user's guide* in the [Probe Resource Center](#).

A Calibrating the Infiniium Oscilloscope and Probe

Index

A

AC Common Mode Noise - PRBS Test, 24
AC Common Mode Noise - Square Wave Test, 19
application software, installing, 8
application software, starting, 13
Automation tab, 14

C

calibrating the oscilloscope, 12, 35
Configure tab, 14
Connect tab, 14
copyright, 2

D

DC Common Mode Output Voltage Test, 18
DCD-Tx, 26
Debug Mode, 33
Differential Peak-to-Peak Output Voltage Test, 20
DJ-Tx, 26

F

fREFCLK, 29

H

HTML Report tab, 14
Hybrid Memory Cube compliance test application, 3

I

installation, 7
ISI Filter Lag, 33
ISI Filter Lead, 33

J

jitter, 26
jitter and signaling rate measurements, 21

jitter and signaling rate specifications, 23
Jitter Pattern Length, 33

L

license key, installing, 9

M

main voltage measurements, 15
main voltage specifications, 16
measurements, preparing, 11

N

notices, 2

O

oscilloscope calibration, 12
oscilloscope internal calibration, 36

P

probe calibration, 37

R

REFCLK measurements, 27
REFCLK specifications, 28
Results tab, 14
return loss ENA/PNA measurements, 31
Rj Bandwidth, 33
RJ-Tx, 26
Run Tests tab, 14

S

Select Tests tab, 14
Set Up tab, 14
signaling rate, 25
signaling rate and jitter measurements, 21
specifications, jitter and signaling rate, 23
specifications, main voltage, 16
specifications, REFCLK, 28

T

tDCD_REFCLK, 30
TJ-Tx, 26

W

warranty, 2

